



EASYMEG

Vertical Standoff Clip Installation Instructions

ABET LAMINATI

Fabricated in the USA 

Thank you for choosing EASY MEG!

EASY MEG is part of the MEG (Material Exterior Grade) product family by ABET LAMINATI. It is specifically crafted for facade cladding applications. Engineered to simplify the installation process across medium to large surfaces, EASY MEG offers unparalleled ease and efficiency in plank installation.

These instructions contain all the information you need to use the product to achieve a professional result correctly and safely. Prior to commencing installation, we strongly advise a thorough review of this installation guide to ensure a successful installation.

For the latest product and technical information visit www.na.abetlaminati.com.

Attention

This product is intended for use by professional installers. Any use outside of the declared scope is deemed inappropriate. ABET offers general guidance and provides all testing, regulatory, and design data for informational purposes only. We strongly advise clients, architects, and project managers to seek independent advice from certified professionals and/or engineers regarding application, installation, and compliance with design requirements, codes, laws, regulations, and testing standards. It is recommended to verify local building codes and design requirements to ensure correct product usage. This document serves as a source of general recommendations only.

Parts Overview

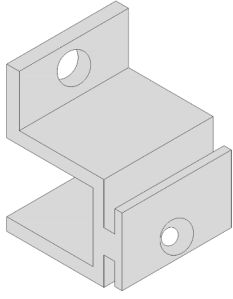

EASY MEG Closed Joint Standoff Clip EZSO

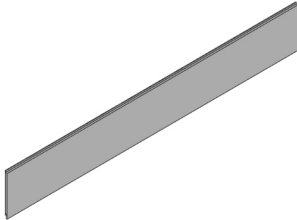

EASY MEG Planks



Metal Screws (Metal Furring)

- **Depending on order selection**
- Dimensions: (#8-18 x 1" Phillips Drive Flat Head
 - 410 Stainless Steel Self Drilling or Equivalent)



Wood Screws (Wood Furring)

- **Depending on order selection**
- Dimensions: (#8-15 x 1" Flat Countersunk head
 - Phillips Drive Sharp Point or Equivalent)

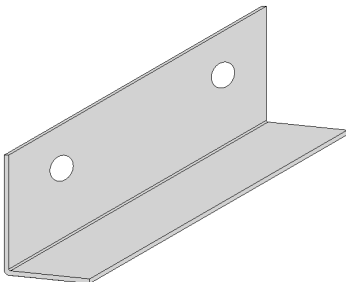

Closed Joint Standoff Support Profile EZSOSP

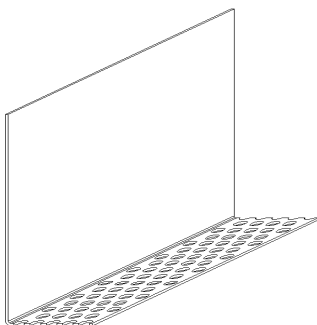

Perforated Sill Flashing XB02

Optional - Depending on order selection

Parts Overview



EPDM Shim w Adhesive
- Dimensions: 1/4" x 1" x 4"

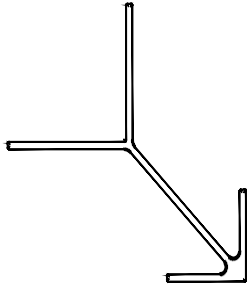

Outside Corner Trim EZOCB
Optional - Depending on order selection

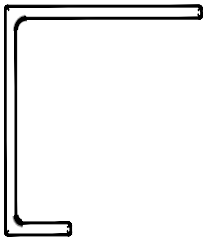

Edge Trim EZETB
Optional - Depending on order selection

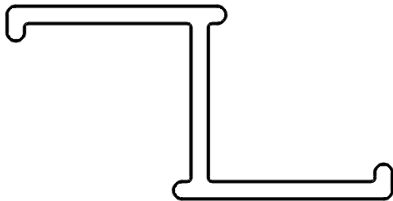

Vertical Z Channel XZB
Optional - Depending on order selection

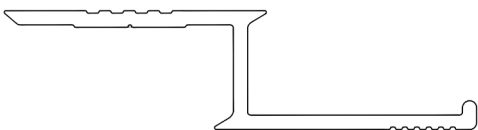

Horizontal Vented Z Channel VXZB
Optional - Depending on order selection, see details for application



Set Point Nail - #17 x 1" wire nail

****Trims can be provided by Abet Laminati upon request.****

Parts Overview

Positioning Tool Set Thickness: (1/16"") or 1 mm Allen Key

Positioning Tool can be provided by Abet Laminati upon request.



Color Matched Screws

Color Matched Screws are provided by others and are available upon request.

Please contact: sales@abetlaminati.com for any questions concerning screws

Additional Requirements:

Wall / Substrate:

- The fasteners should be chosen to suit the appropriate wall substrate and must be designed by the architect/engineer of record.
- Typical wall substrate includes sheathing with wood or metal studs, CMU or solid concrete.
- Fasteners should be selected to penetrate the wall structure, not just exterior sheathing.
- **Fastening:** Ensure that fasteners are installed according to the diameter and embedment specified in the calculations. For fasteners into wood framing, adhere to the design standards outlined in the American Forest & Paper Associations “National Design Specification” (NDS). 2024.
- **Plywood Requirements:** Use plywood that is C-D grade or better and a minimum thickness of 1/2 inch.
- **OSB Requirements:** Use OSB with a minimum thickness of 1/2 inch.
- For fastening requirements, consult Abet’s technical service team.

****Fasteners into the wall/substrate by others****

Substructure

- Wood - EPDM Rubber Weatherproofing Material is recommended.
- Extruded Structural Aluminum - Minimum 0.09-inches 6005 T5 or equivalent.
- Steel - Minimum 16-Gauge G90 Galvanized or equivalent prior to installation.

Ventilation

- Ventilation Gap minimum of 1” (25mm)
- Vertical Joint Gap minimum of 1/4” (6.35mm) Clip Spacing Maximum of 24” O.C.
- Edge Clearance: Maximum of 2” from Edge of Plank to Center of Clip

****Peel Coat must be removed from BOTH sides of the plank prior to install.****

General Installation Instructions

1. Ventilation Requirements

ABET requires the cavity depth between the wall or insulation and the cladding to be 1" (25mm) to allow for ambient air flow and proper moisture wicking.

2. Clip

A) Distance between clips cannot exceed 24" on center.

B) The first row of clips should be positioned with a spirit level or laser tool.

C) Use the Positioning Tool, 1mm Allen Key, when mounting clips to ensure the (1/16") space between the clip and plank is maintained to allow for hygrothermal expansion and contraction of the plank.

3. Screws

A) **The screws that are provided in the EASY MEG packaging are based upon request for aluminum or wood sub framing.**

B) **Please contact: sales@abetlaminati.com for any questions concerning screws.**

4. Closed Joint Support Profile (Ezsosp)

A) The lower part of each plank should be supported by EZSOSP.

B) The support profile should be fastened at both points. For fastening requirements, consult Abet's technical service team.

C) Fix the support profile 8mm above the lower siding.

5. Trims (Edge trim EZETB - EASY MEG Outside Corner EZOCB)**Optional**

A) Install each trim profile in its designated location using the suitable fasteners compatible with the substructure. The choice of screws should align with the type of substructure being utilized.

B) Ensure that these trims are installed plumb and level, and adjustments can be made by shimming up to 1/4". The precise placement of the fastener on each flange can be determined by the installer.

6. Perforated Sill Flashing (XB02) **Optional**

A) The perforated sill should be attached at 16"-24" O.C maximum and should be level.

7. Terminations

A) Measure the length and width of the area to be covered and field cut the planks down to the proper sizes accordingly.

B) To ensure the planks remain flush and plumb, shims may be necessary between the plank and furring. (Shims to be provided by the installer).

C) If adding a coping trim, Abet requires that a 3/8" gap off the face of the plank be maintained to allow for proper ventilation.

D) Please Reference Detail Set for more information.

Fixing Details (Plan View):

1. EASY MEG Plank
2. EASY MEG Standoff Clip
3. Color Matched Screw
A) Not included in packaging, available upon request)
4. Substructure XZB Furring (0.90" - 6005-T5 Alum.)
5. Edge Trim EZETB ****Optional****

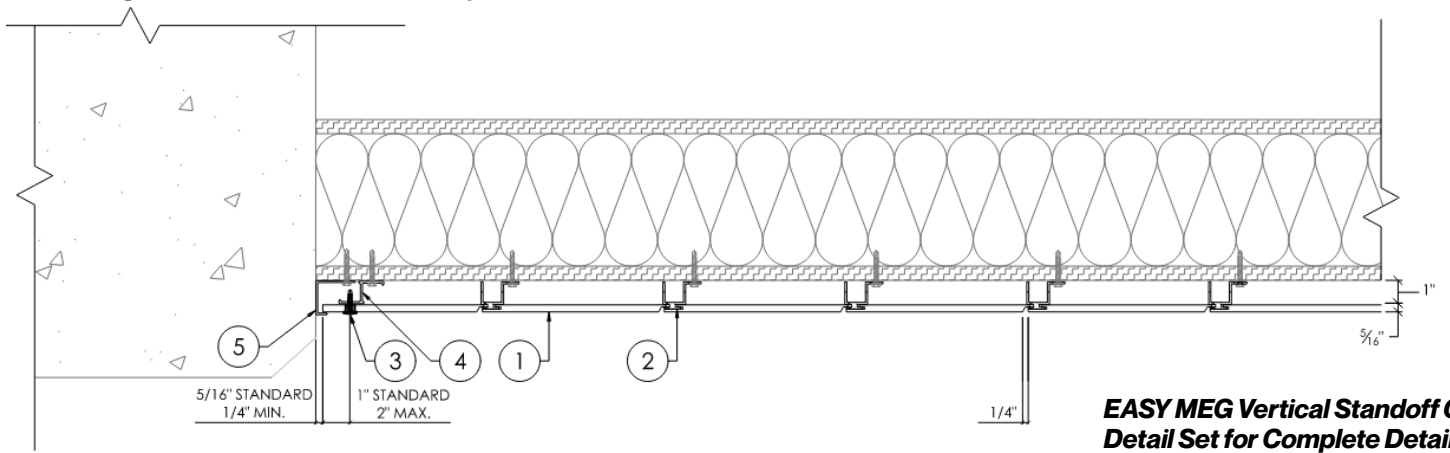

**EASY MEG Vertical Standoff Clip
Detail Set for Complete Details***

Corner Details (Plan View):

- A) Building Corners can be made with free side planks or with a protective/ decorative trim.
- B) Trims are not included in the EASY MEG Packaging, but are available upon request.

Outside with trim

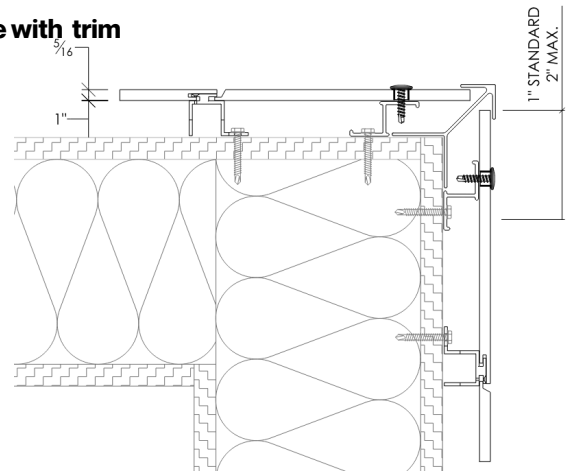

Outside

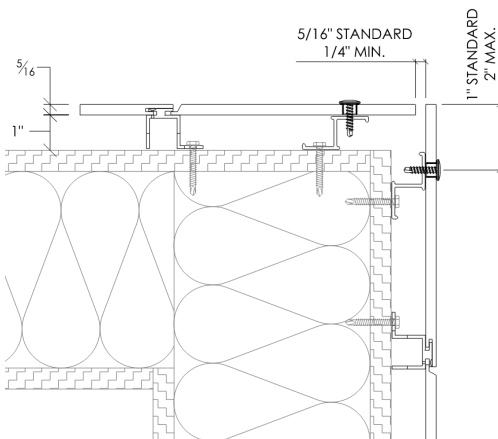

Inside

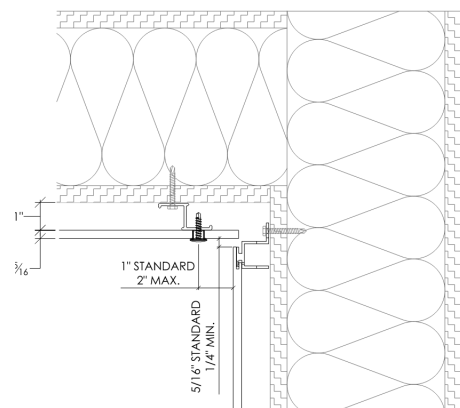

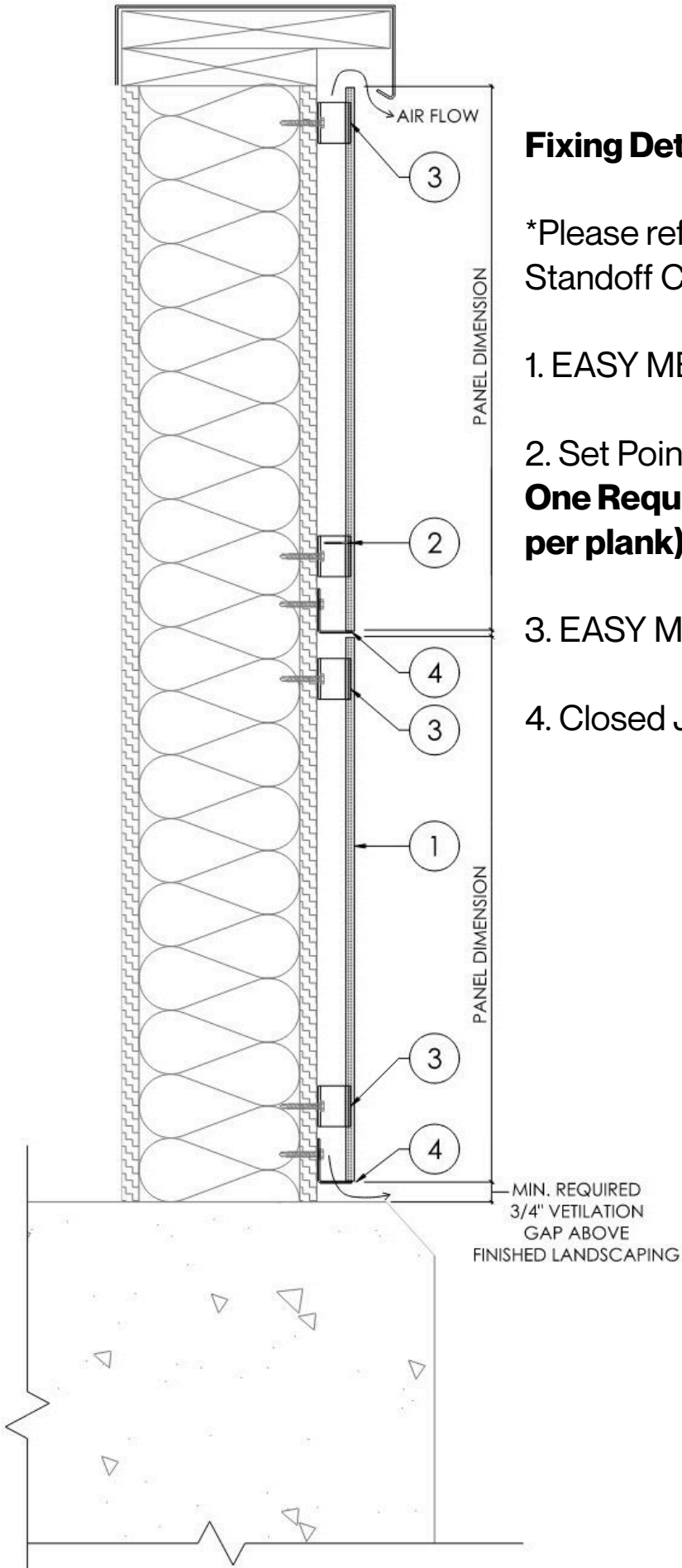

Fixing Details (Section View):

*Please reference the EASY MEG Vertical Standoff Clip details set for complete details.

1. EASY MEG Plank
2. Set Point Nail at the bottom clip of the plank.
One Required Per Plank (not to exceed one per plank).
3. EASY MEG Standoff Clip
4. Closed Joint Support Profile EZSOSP

Step 1

Prepare the wall

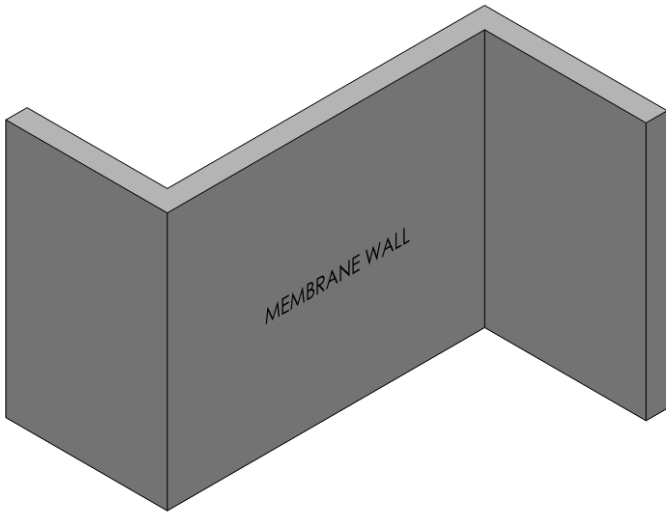

- Ensure that the weather resistant barrier has been installed in accordance with the specific requirements outlined for the project.

Step 2

Installation of Trims (Edge Trim EZETB - EASY MEG Outside Corner EZOCB (if no trims are being used proceed to step 3))

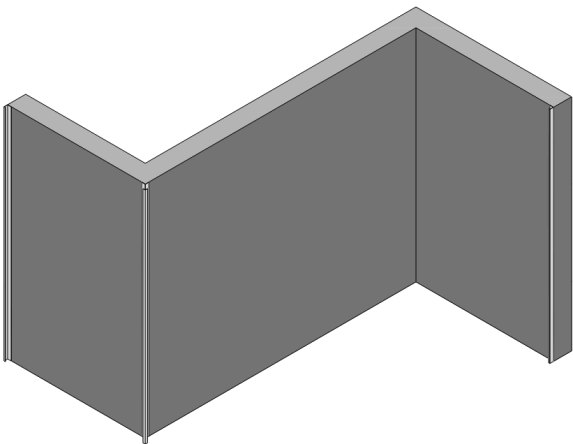

- Use a laser or spirit level to install each trim profile in their appropriate locations using the appropriate screws for the wall substrate. The trims should be a minimum of $\frac{3}{4}$ " above the finished landscaping wall. These trims should be installed plumb level.
- Placement of the fastener on each flange can be determined by the installer.

Step 3

Installation of Perforated Sill Flashing XB02 **Optional**

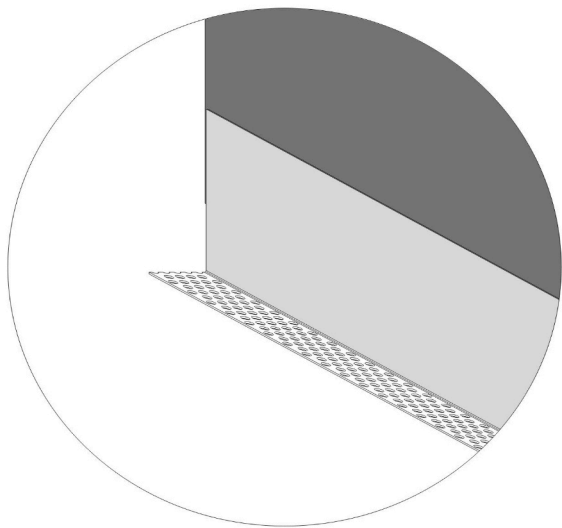
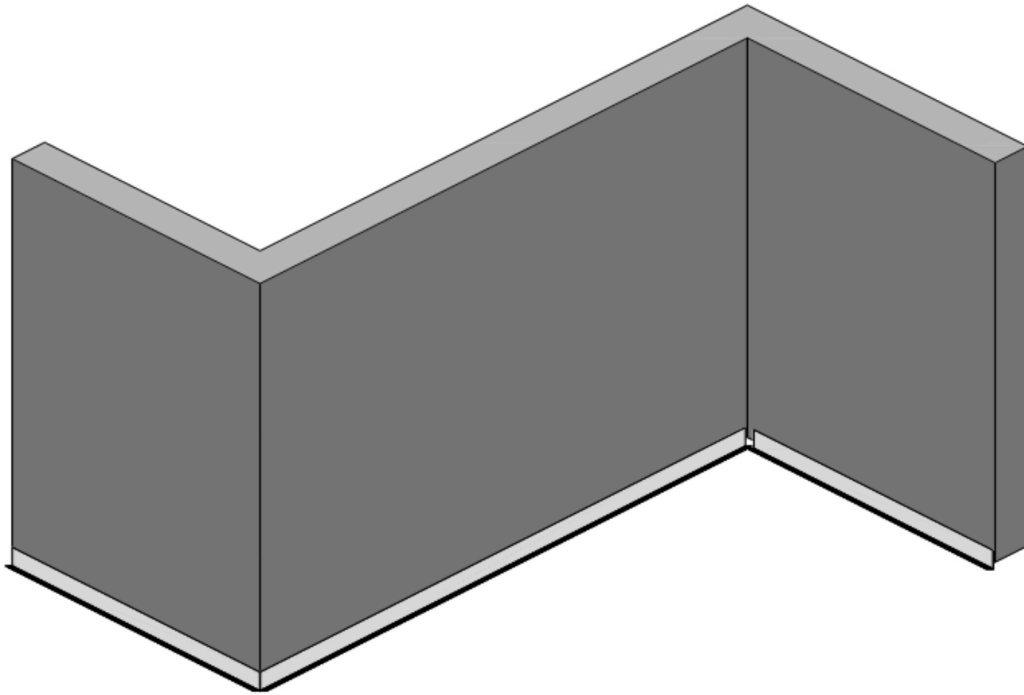

- Use a laser level or spirit level to install the XB02 at the bottom of the wall a minimum of 3/4" above the finished landscaping to ensure unobstructed air flow.
- Starting at the bottom of the wall install XB02 a minimum of 3/4" ABOVE the finished landscaping to ensure the required unobstructed air flow behind the planks.

***Please reference the EASY MEG vertical Standoff Clip detail set for complete details.**

The perforated sill XB02 should be attached at each stud, 16-24" O.C maximum, and should be level.

Step 4

- Using a laser or spirit level install the clips starting vertically at the bottom of the wall. Distance between clips cannot exceed 24" on center and the rear flange clips should be mounted in the direction of the installation.
- The bottom section of each plank must be supported by the EZSOSP. Identify the center of the plank and install the support profile. The support profile should be placed at the bottom part of the first plank and at all intermediate joints to prevent the EASY MEG Planks from sliding down.
- The support profile should be fastened at both points.
- Fix the support profile 8mm above the lower siding.

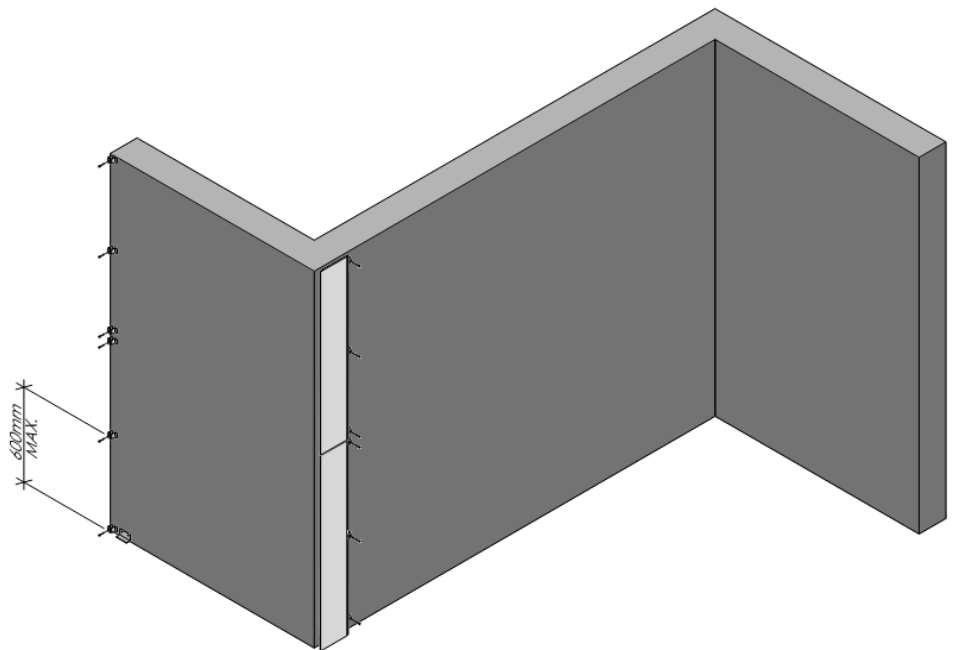
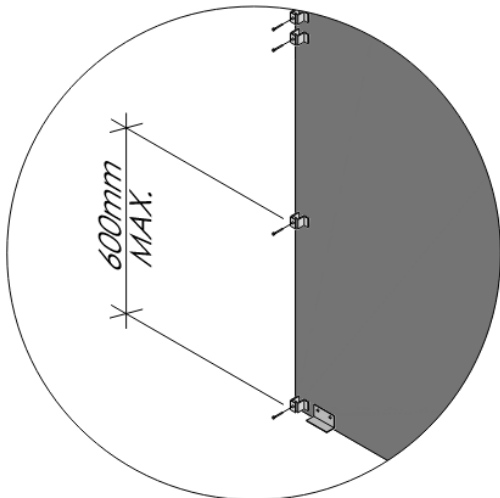
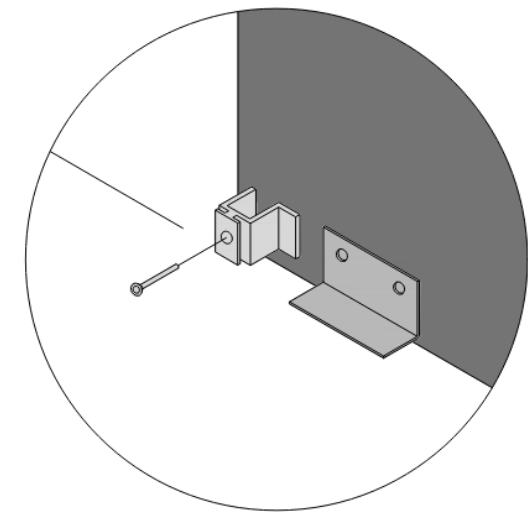

Step 5

Install The EASY MEG Plank Vertically

- Remove peel coat from both sides of the plank before installing on the wall.
- Slide/Sit EASY MEG Planks into the first row of installed clips. Using a laser level or spirit level verify that the EASY MEG Plank is installed level.
- The EASY MEG Closed Joint System is designed to allow for expansion and contraction of the planks. Use the positioning tool 1MM allen key to allow for 1/16" (1.6mm) of space between the top edge of the plank and the clip.
- Set Point Nail at the bottom clip of each plank. One required per plank (not to exceed one per plank).
- **Maintain a minimum distance of 1/4" between planks to accommodate hygrothermal movement of the plank. Please reference system details for more information.**

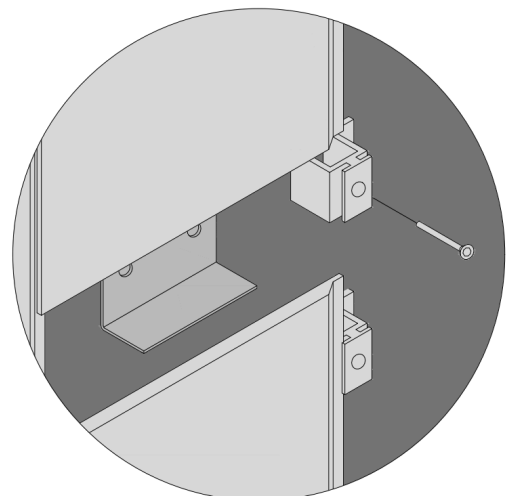
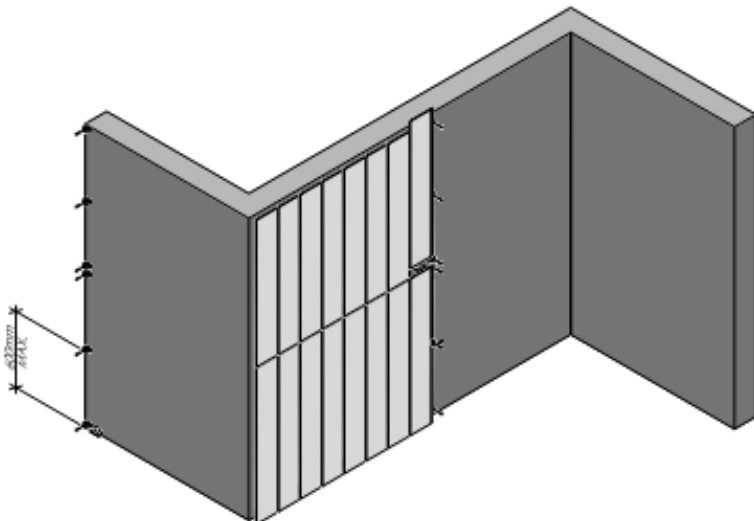
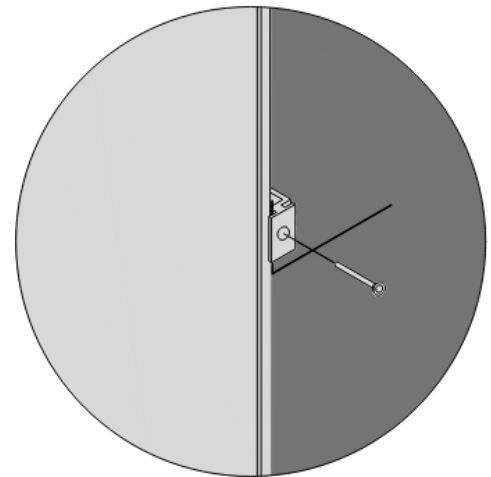
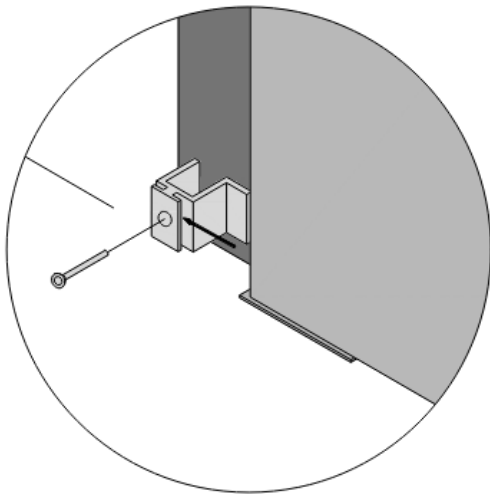

Step 6

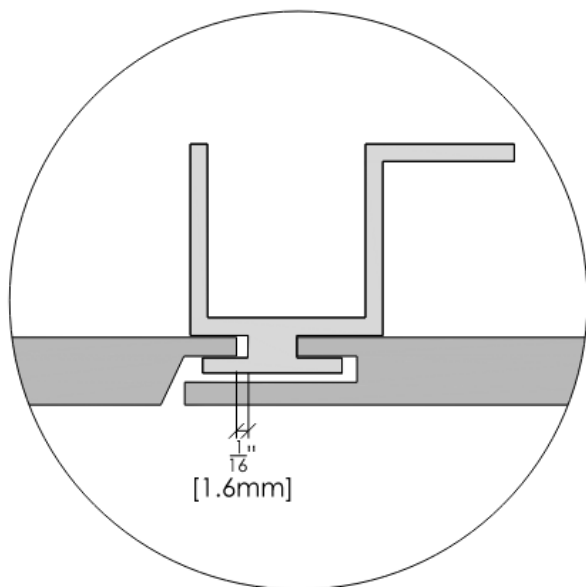
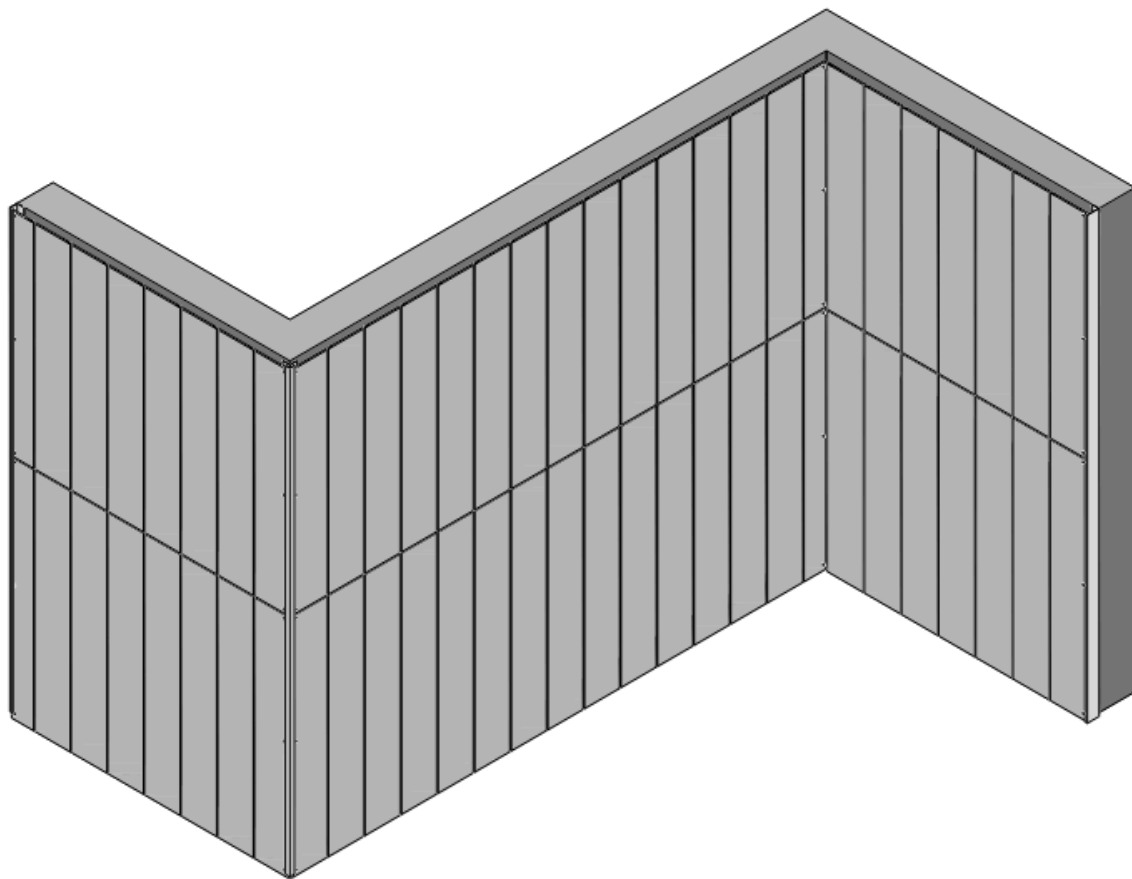

- Continue to install the EASY MEG planks with the same methodology until the desired surface is covered.
- **Maintain a minimum distance of $\frac{1}{4}$ " between planks to accommodate hygrothermal movement of the plank. Please reference system details for more information.**
- Planks can be field cut at termination locations. Planks must be cut face down
- When drilling planks, make sure to have sacrificial material underneath to prevent panel blowout.

Step 7

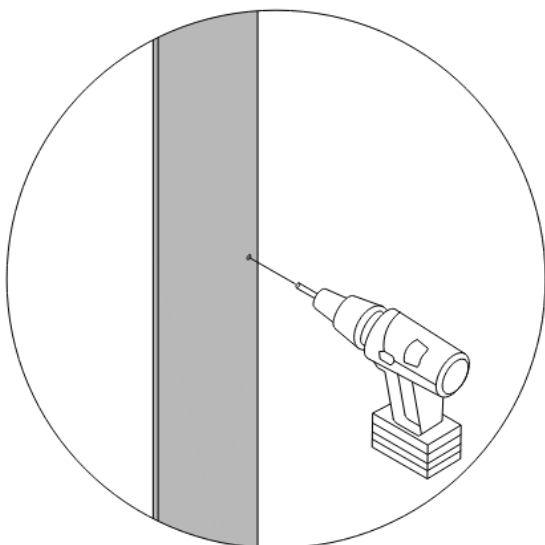
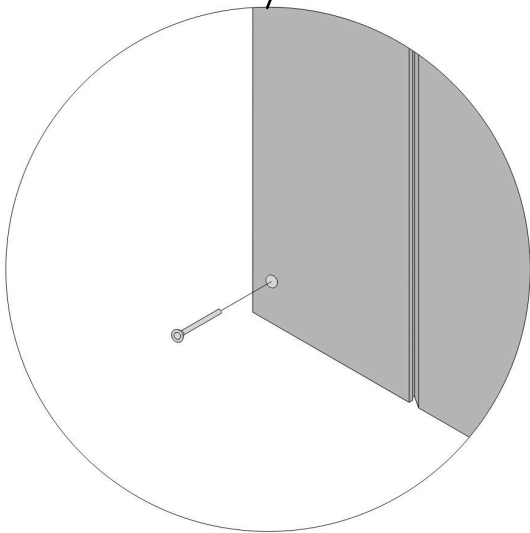
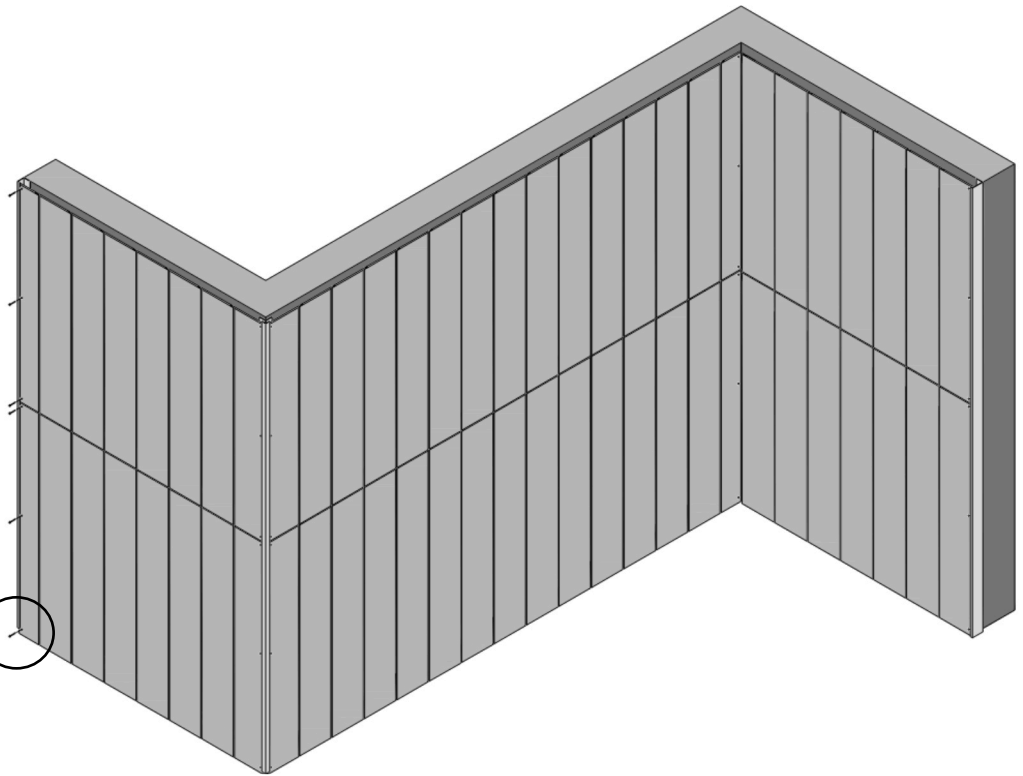

Termination Drilling Guidelines:

- Drill 1 fixed point hole $7/32"$ (5.5mm) at the bottom of the plank.
- The remaining holes are to be drilled as floating holes $5/16"$ (8mm). This is to allow for proper expansion and contraction of the plank.
- When drilling planks, make sure to have sacrificial material underneath to prevent panel blowout
- Shim as necessary to keep plank plumb to the wall.

Closing Flashing

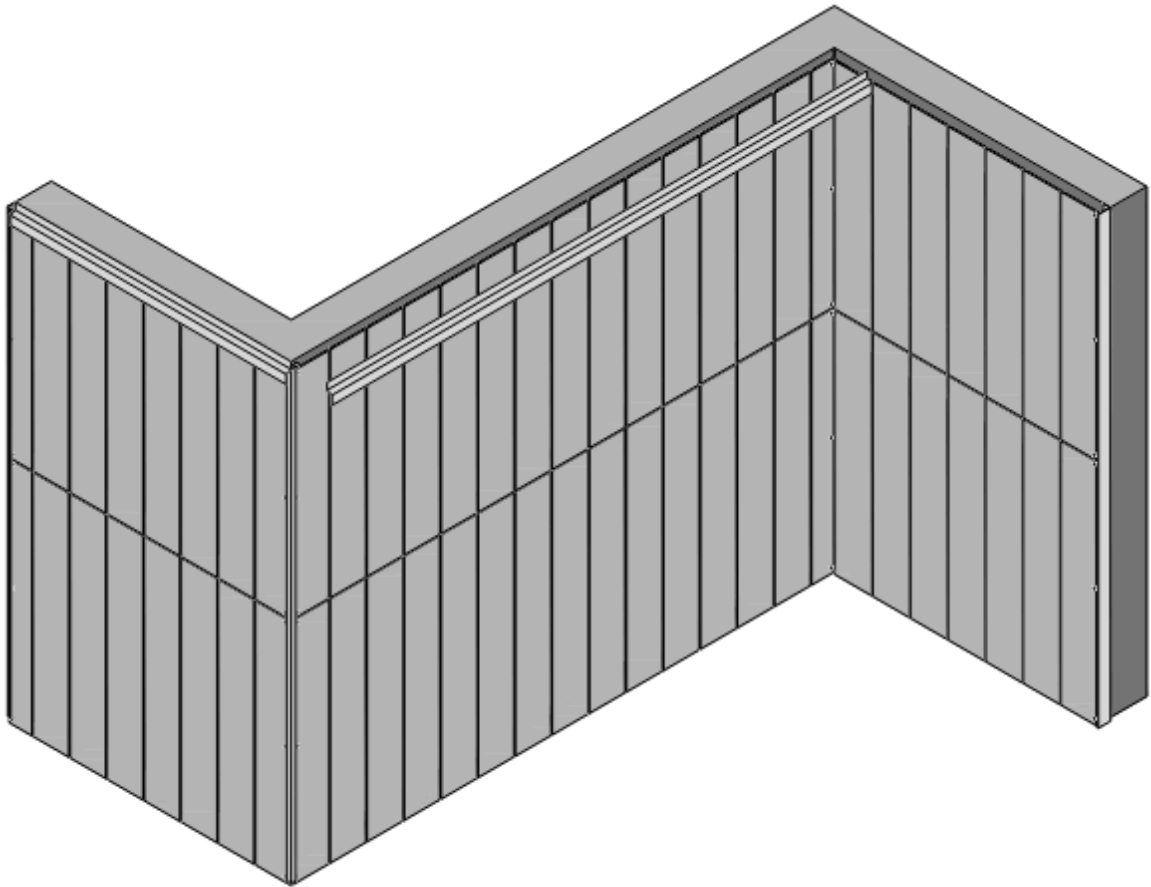

- If installing a top flashing or coping leave 1" vertical air space above top plank and 3/8" spacing off the face of the plank to allow for proper ventilation.
- Bottom Flashings can be used with the system but must be perforated to allow for air flow into the system.

ABET can provide flashings upon request for your project.

Disclaimer

Article 1 - Object

1.1 The present guarantee for MEG and MEG F1 products by Abet Laminati S.p.A. (the «MEG Warranty»), is additional to the provisions of the 'General Conditions of Sale and Guarantee Abet', of which the MEG Warranty constitutes an attachment and which are fully applicable to MEG / MEG F1 products, except as expressly herein expected for these products. The terms and expressions conventionally defined in the 'General Conditions of Sale and Warranty Abet' have the same meaning also in the MEG Warranty, unless otherwise indicated.

1.2 With the MEG Guarantee, Abet guarantees the resistance of the panels produced in laminated material called MEG and MEG F1 (the«MEG Products») to the elements, with this being the behaviour of the laminates in relation to surface degradation, colour fading and reduction of mechanical properties due to exposure to atmospheric agents (sunlight, rain, frost, etc. 1.3 The MEG Warranty will have a duration of 10 years from the date of delivery to the Customer of the MEG Products and will be valid according to the terms, conditions and methods indicated above.

Article 2 - Applicability of the MEG Warranty

2.1 The MEG Guarantee applies to the MEG Products that are defective with reference to the standards set by the reference standard UNI EN 348: 2016-6, the Technical Manual of the MEG Products (the «Manual») and the MEG Product Information Sheet, (the «Card») both delivered to the Customer together with the MEG Products, and in any case available at www.abetlaminati.com.

2.2 The MEG Warranty will only be valid for the MEG Products installed by following the storage, processing, assembly and maintenance instructions outlined in the {MEG Product Information Sheet.}.

2.3 If the MEG Products are to be installed in Countries other than Italy, the Customer is obliged to check applicable local regulations. In the event that a defect appears to be covered by this MEG Warranty but which is caused by failure to comply with the aforementioned legislation, then the MEG Warranty will not be applicable. In addition, if the MEG Products are installed in compliance with local regulations but these regulations do not conform to the guidelines in the MEG Product Information Sheet, then the MEG Warranty will also not be applicable.

2.4 The defects of the MEG Products must be proven by an accredited external third party (a well-known conformity assessment body and/ or a consultant recognised world-wide as an expert in the HPL sector) at the expense of the Customer. To this end, the Customer will be required to consent, that is, in the event that the MEG Products have been assembled on the property of third parties, to ensure that it is consented by them, to Abet or to the person appointed by Abet, to inspect the Products MEG in question as well as to examine the drawings and documents related to the construction project and the methods of installation of the MEG Products in order to promptly assess the request for compensation based on the MEG Warranty.

2.5 The MEG Warranty is applicable on the condition that the defects are reported in writing, providing a clear and detailed description of the defects in question, within 30 days of their discovery. The Purchase Order sent to Abet or an authorised dealer or distributor of the MEG Products and the relevant invoices of the MEG Products must be attached, under penalty of validity of the MEG Warranty.

2.6 If the existence of the defects reported is confirmed without prejudice to the provisions of Article 4 of this MEG Warranty, Abet shall have the right to choose between the replacement of defective MEG Products and the reimbursement of the amount paid by the Customer. In the event that Abet chooses to replace the MEG products but the chromatic reference and / or the finish are no longer available, Abet has the right to propose others as similar as possible to the original decoration and / or finish, even if not exactly the same.

2.7 The replacement of the defective MEG Products does not, in any case, extend the original warranty period outlined in point 1.3 (i.e. 10 year from the date of first delivery).

Article 3 - Exclusion of the MEG Warranty

3.1 The MEG Warranty does not cover:

(i) the physiological effects of the ageing process of the MEG products, such as, by way of nonexhaustive ex-ample, a slow discolouration or a slight variation in the brightness of the colour;

(ii) MEG Products mounted horizontally or on inclined sur-faces (except for use in outdoor roofs) when exposed directly to atmospheric agents and / or sunlight and in the absence of proper ventilation and drainage on the back of the panels of the MEG products; any material damage to persons or property deriving from the fall of MEG Products panels due to the fixing or installation system or damage from vandalism, neg-ligence, abuse, war, natural disasters, terrorist acts and force majeure;

any damage to parts of the building on which MEG Products have been installed, such as, but not limited to, extensions of roofs, cornices, windows and seals of windows, doors, posters, billboards, lights, surroundings of the building and any other type of accessory connected to the building;

reimbursement of decoration costs of any kind, roofing materials and / or other materials for facades, dismantling and reinstallation of blinds, awnings and / or awnings, lights, signs, scaffolding for window cleaning and other similar costs of any kind, including, but not limited to, the cost of dismantling, repairing and / or reinstalling a load-bearing structure and / or other building parts.

EASY MEG by **ABET LAMINATI** is
proudly fabricated at our facility in
Oconomowoc, Wisconsin.



ABET LAMINATI

ABET LAMINATI

N48W373031 E Wisconsin Avenue
Oconomowoc, WI 53066
262.567.4427

www.na.abetlaminati.com

Copyright 2021
© Abet Laminati
S.p.A. All rights
reserved

ABET LAMINATI